

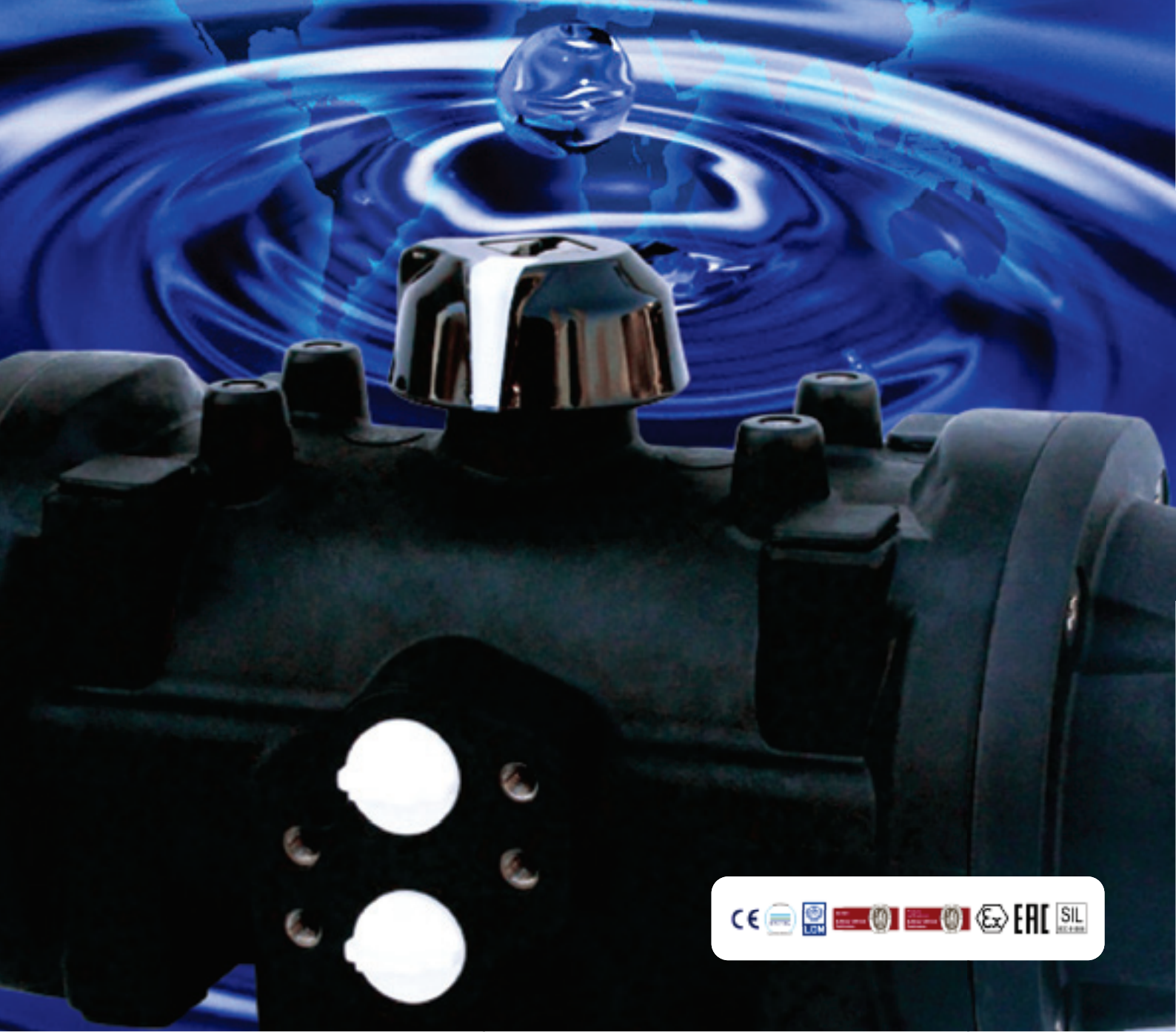

**Actuadores Neumáticos Rotativos -POLIAMIDA-  
Rotary Pneumatic Actuators -POLYAMIDE-**



ACTUADORES NEUMATICOS DE POLIAMIDA -INDICE-  
PNEUMATIC ACTUATORS IN POLYAMIDE -INDEX-

GENERALIDADES FEATURES	-----	N-GPP
PPW-PWS PPW-PWS	-----	N-PPW
PP00-PP00S PP00-PP00S	-----	N-PP00
PP10-PP10S PP10-PP10S	-----	N-PP10
PP20-PP20S PP20-PP20S	-----	N-PP20

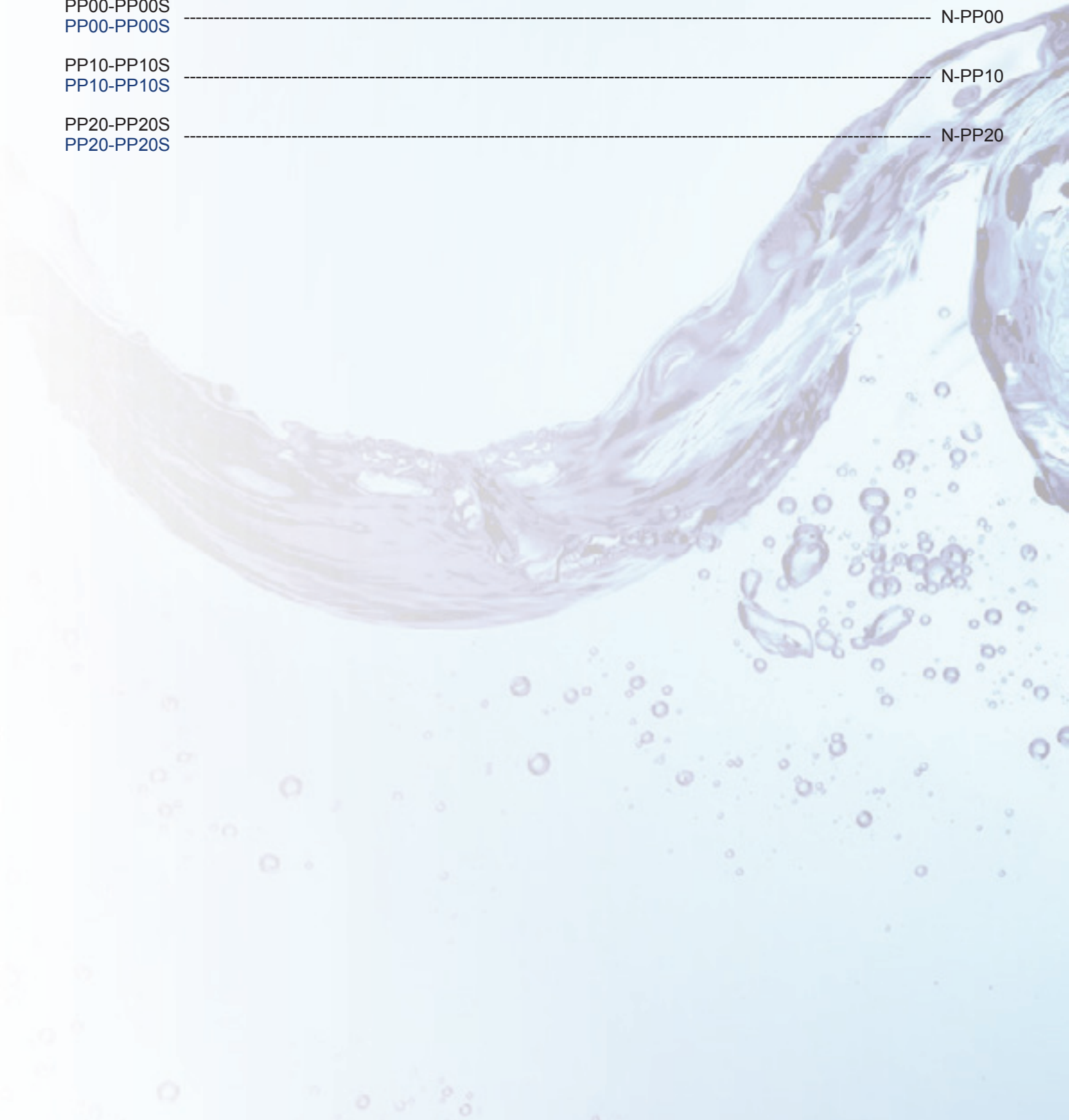

## **ACTUADORES NEUMATICOS DE PLÁSTICO INDUSTRIAL** **PNEUMATIC ACTUATORS IN INDUSTRIAL POLYAMIDE**

**Para automatizar válvulas de bola, mariposa o macho cónico.**  
**To pilot ball, butterfly and plug valves.**

- Diseño especial para válvulas de plástico o cristal. Ligeros de peso y muy resistentes a la corrosión. Exentos de silicona.
- Special design to fit to glass and composite valves. Light weight and very resistant to corrosion. Silicone free.
- Temperatura normal de funcionamiento: -32°C hasta 90°C.
- Normal working temperature: -32°C to 90°C.
- Modelos de simple y doble efecto con pares de 17Nm a 165Nm a 6 bar.
- Models in spring return and double acting, torques from 17Nm up to 165Nm at 6 bar.
- Pueden ser accionados con aire, agua o fluido no agresivo hasta 8 bar de presión. Aptos para instalaciones marinas y subacuáticas.
- May be actioned with air, water or nonagressive fluid up to 8 bar pressure. Fit for marine and underwater installations.
- Normas de construcción: ISO-5211, DIN-3337, VDE-3845, NAMUR.
- Norms of construction: ISO-5211, DIN-3337, VDE-3845, NAMUR.
- Los Actuadores Neumáticos cumplen los requisitos aplicables a las Directivas PED 97-23-CE, ATEX 94-9-CE y IEC 61508: SIL3.
- Pneumatic Actuators according to PED 97-23-EC, ATEX 94-9-EC and IEC 61508: SIL3 Directives.
- Pueden ser equipados con finales de carrera, electroválvulas, posicionadores, y mando manual por volante o reductor desembragable.
- May be equipped with limit switches, solenoid valves, positioners and manual override by wheel or unclutchable gearbox.
- Amplia gama de acoplamientos para adaptar el actuador a la mayoría de válvulas.
- Broad range of couplings to adapt the actuator to the majority of valves.
- De aplicación preferente en Plantas Depuradoras, Tratamientos de Aguas, Industria Agroquímica, Textil, Enológica, Pasta y Papel, Refinerías, Automatización de Riegos,...
- Of preferent application in Water Treatment Plants, Agrochemical Industry, Textile, Enologic, Pulp and Paper, Refineries, Automation of irrigation,...

MECÁNICA PRISMA, S.L.  
C/ Telègraf 1-7  
Polígon industrial Sota el Molí  
08160 - Montmeló (Barcelona)  
SPAIN

Tel: (+34) 93 462 11 54  
Fax: (+34) 93 462 12 74

prisma@prisma.es  
www.prisma.es



DESPIECE

DISASSEMBLY



ACTUADOR NEUMÁTICO DE POLIAMIDA  
POLYAMIDE PNEUMATIC ACTUATOR



Nº	Descripción Description	Cant. Quant.	Material Material
1	TORNILLO AVELLANADO TAPA CAP COUNTERSUNK SCREW	8	ACERO INOXIDABLE AISI-304 AISI-304 STAINLESS STEEL
2	TAPA CAP	2	POLIAMIDA + FV POLYAMIDE + FG
3	JUNTA TÓRICA TAPA CAP-O-RING	2	N.B.R. N.B.R.
4	ÉMBOLO PISTON	2	POLIARILAMIDA POLYARILAMIDE
5	CILINDRO CYLINDER	1	POLIAMIDA + FV POLYAMIDE + FG
6	ARANDELA WASHER	1	POLIACETAL POLYACETAL
7	ANILLO DE SEGURIDAD SPRING CLIP	1	ACERO INOXIDABLE STAINLESS STEEL
8	INDICADOR VISUAL POSITION INDICATOR	1	POLIACETAL POLYACETAL
9	ANILLO GUIA GUIDE RING	2	POLIACETAL + Mb POLYACETAL + Mb
10	JUNTA TÓRICA ÉMBOLO PISTON O-RING	2	N.B.R. N.B.R.
11	JUNTA TÓRICA O-RING	2	N.B.R. N.B.R.
12	JUNTA TÓRICA O-RING	1	N.B.R. N.B.R.
13	MUELLES PRECARGADOS PRELOADED SPRINGS	12	DIN-17223-C (6) (4) DIN-17223-C (6) (4)
14	EJE SHAFT	1	POLIAMIDA + INSERTO INOX. POLYAMIDE + S.S INSERT
15	DADO DE CONEXIÓN DRIVE ADAPTER	1	ACERO INOXIDABLE STAINLESS STEEL
16	INSERTOS ROSCADOS SHAFT	10	ACERO INOXIDABLE STAINLESS STEEL

PPW: Doble Efecto / Double Acting  
PPWS: Simple Efecto / Spring Return

(4) CANTIDAD VARIABLE, CONSULTAR TABLAS PARES SIMPLE EFECTO.  
VARIABLE QUANTITY, PLEASE SEE THE SPRING RETURN TORQUE CHART.  
(6) PASIVADO DE CROMO TRIVALENTE.  
TRIVALENT CHROMINIUM PASSIVATION.

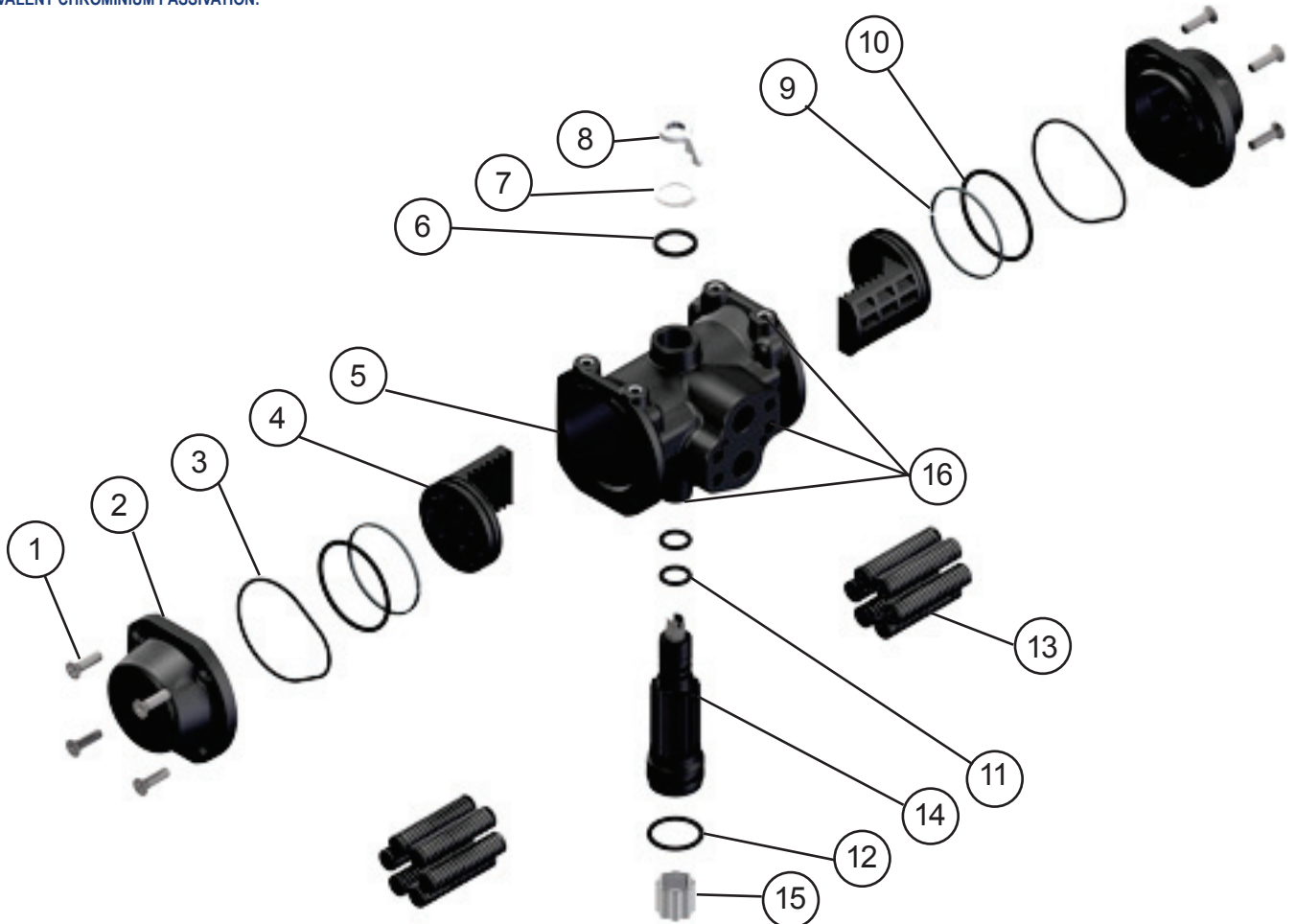

MODELOS MODELS	TIEMPO DE MANIOBRA EN SEG. CYCLE TIME IN SECS.		PESOS WEIGHTS		CAPACIDAD EN LITROS CAPACITY IN LITRES	
	PARA ABRIR TO OPEN	PARA CERRAR TO CLOSE	Kg.	Lb.	PARA ABRIR TO OPEN	PARA CERRAR TO CLOSE
PPW	0,1	0,1	0,47	1,04	0,075	0,05
PPWS	0,15	0,15	0,55	1,21	0,075	

Tiempo de maniobra sin par resistente a 6 bar.  
Cycle time w/o resistant torque at 6 bar.

Dimensiones en mm.  
Dimensions in mm.

Para calcular el consumo, multiplicar las cifras del cuadro por la presión real de trabajo.

To calculate the consumption, multiply the above figures by the real working pressure.

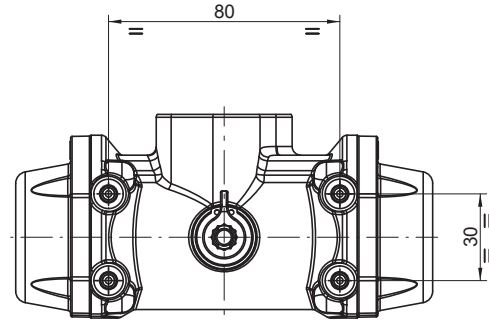
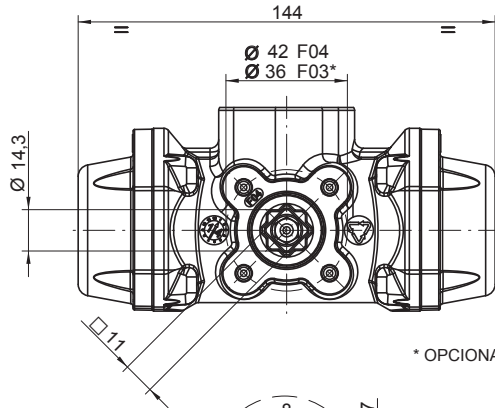

\* OPCIONAL / OPTIONAL

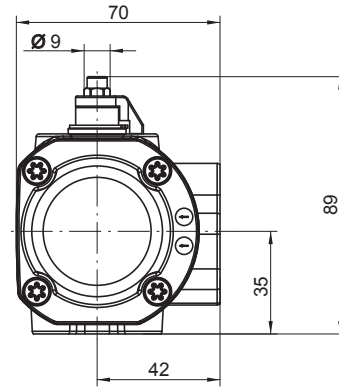
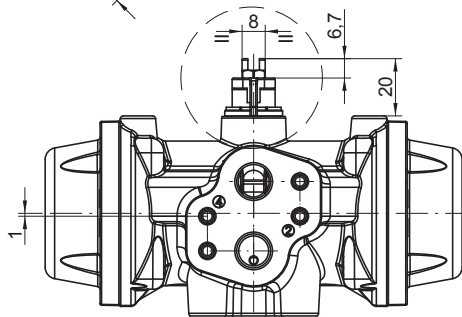

### PARES DOBLE EFECTO DOUBLE ACTING TORQUES

PPW	PRESION AIRE AIR PRESSURE						
bar	3	4	5	5,5	6	7	8
p.s.i	43,5	58	72,5	79,8	87	101,5	116
Nm	7,9	11,3	14,1	15,5	17	19,8	22,9
Lb.in	69,3	100	124,8	137,2	150,5	175,2	202,7

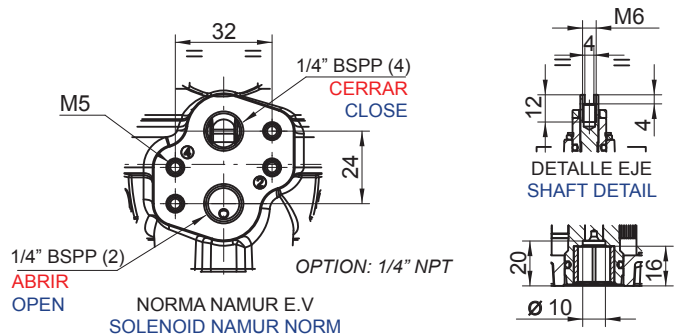

### PARES SIMPLE EFECTO SPRING RETURN TORQUES

PPWS	PAR MUELLES SPRING TORQUES	PAR A LA PRESIÓN INDICADA AIR TORQUE AT INDICATED PRESSURE															
		3		4		5		5,5		6		7		8		bar	
		43,5		58		72,5		79,8		87		101,5		116		p.s.i	
N	INICIAL INITIAL	FINAL END	INICIAL INITIAL	FINAL END	INICIAL INITIAL	FINAL END	INICIAL INITIAL	FINAL END	INICIAL INITIAL	FINAL END	INICIAL INITIAL	FINAL END	INICIAL INITIAL	FINAL END	INICIAL INITIAL	FINAL END	
6*	10	6,7					7,4	4,1	8,8	5,5	10,3	7	13,1	9,8	16,2	12,9	Nm
	88,5	59,3					65,5	36,3	77,9	48,7	91,2	62	115,9	86,7	143,4	114,2	Lb.in
5	8,5	5,8			5,5	2,8	8,3	5,6	9,7	7	11,2	8,5	14	11,3	17,1	14,4	Nm
	75,2	51,3			48,7	24,8	73,5	49,6	85,9	62	99,1	75,2	123,9	100	151,3	127,5	Lb.in
4	7	4,6	3,3	0,9	6,7	4,3	9,5	7,1	10,9	8,5	12,4	10	15,2	12,8	18,3	15,9	Nm
	62	40,7	29,2	8	59,3	38,1	84,1	62,8	96,5	75,2	109,7	88,5	134,5	113,3	162	140,7	Lb.in
3	5,5	3,6	4,3	2,4	7,7	5,8	10,5	8,6	11,9	10	13,4	11,5	16,2	14,3			Nm
	48,7	31,9	38,1	21,2	68,2	51,3	92,9	76,1	105,3	88,5	118,6	101,8	143,4	126,6			Lb.in
2	4	2,4	5,5	3,9	8,9	7,3	11,7	10,1	13,1	11,5	14,6	13					Nm
	35,4	21,2	48,7	34,5	78,8	64,6	103,6	89,4	115,9	101,8	129,2	115,1					Lb.in

N: Número de muelles por banda  
Number of springs per side

\* Número de muelles estándar  
\* Standard number of springs

DESPIECE

DISASSEMBLY



Nº	Descripción Description	Cant. Quant.	Material Material
1	TORNILLO AVELLANADO TAPA CAP COUNTERSUNK SCREW	8	ACERO INOXIDABLE AISI-304 AISI-304 STAINLESS STEEL
2	TAPA CAP	2	POLIAMIDA + FV POLYAMIDE + FG
3	JUNTA TÓRICA TAPA CAP-O-RING	2	N.B.R. N.B.R.
4	ÉMBOLO PISTON	2	POLIARILAMIDA POLYARILAMIDE
5	CILINDRO CYLINDER	1	POLIAMIDA + FV POLYAMIDE + FG
6	ARANDELA WASHER	1	POLIACETAL POLYACETAL
7	ANILLO DE SEGURIDAD SPRING CLIP	1	ACERO INOXIDABLE STAINLESS STEEL
8	INDICADOR VISUAL POSITION INDICATOR	1	POLIAMIDA POLYAMIDE
9	GUIA ÉMBOLO PISTON GUIDE	2	POLIACETAL POLYACETAL
10	ANILLO GUIA GUIDE RING	2	POLIACETAL POLYACETAL
11	JUNTA TÓRICA ÉMBOLO PISTON O-RING	2	N.B.R. N.B.R.
12	JUNTA TÓRICA O-RING	2	N.B.R. N.B.R.
13	JUNTA TÓRICA O-RING	2	N.B.R. N.B.R.
14	MUELLES PRECARGADOS PRELOADED SPRINGS	12	DIN-17223-C (6) (4) DIN-17223-C (6) (4)
15	PROTECTOR / TUERCA PROTECTOR / NUT	8	POLIAMIDA / INOX AISI-304 POLYAMIDE / S.S. AISI-304
16	EJE SHAFT	1	ACERO INOX. AISI-303 AISI-303 STAINLESS STEEL
17	INSERTOS ROSCADOS THREAD INSERTS	10	ACERO INOXIDABLE STAINLESS STEEL

ACTUADOR NEUMÁTICO DE POLIAMIDA  
POLYAMIDE PNEUMATIC ACTUATOR



PP00: Doble Efecto / Double Acting

PP00S: Simple Efecto / Spring Return

(4) CANTIDAD VARIABLE, CONSULTAR TABLAS PARES SIMPLE EFECTO.  
VARIABLE QUANTITY, PLEASE SEE THE SPRING RETURN TORQUE CHART.  
(6) PASIVADO DE CROMO TRIVALENTE.  
TRIVALENT CHROMINIUM PASSIVATION.

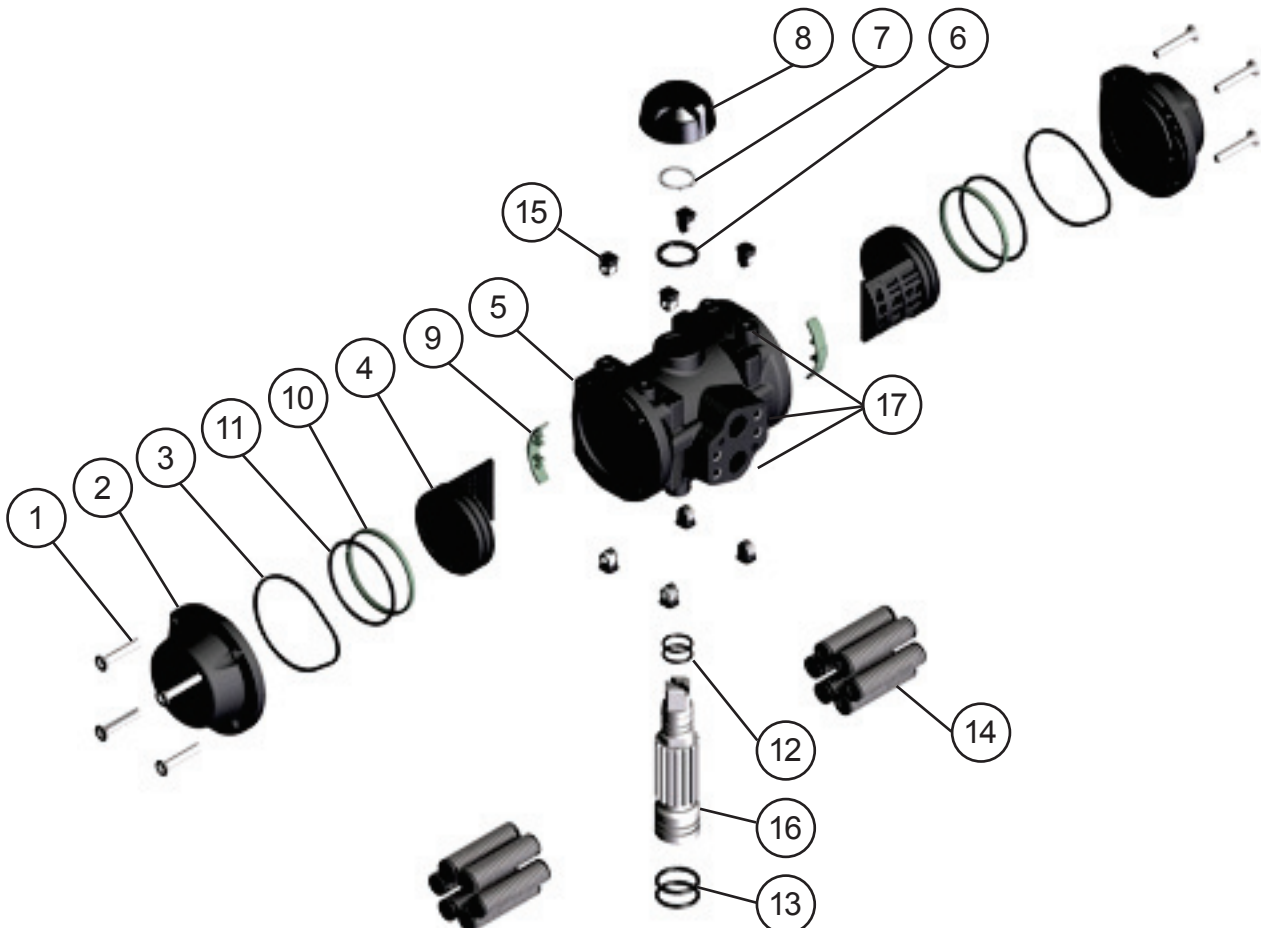

MODELOS MODELS	TIEMPO DE MANIOBRA EN SEG. CYCLE TIME IN SECS.		PESOS WEIGHTS		CAPACIDAD EN LITROS CAPACITY IN LITRES	
	PARA ABRIR TO OPEN	PARA CERRAR TO CLOSE	Kg.	Lb.	PARA ABRIR TO OPEN	PARA CERRAR TO CLOSE
PP00	0,15	0,15	0,83	1,83	0,15	0,18
PP00S	0,2	0,2	1	2,20	0,15	

Tiempo de maniobra sin par resistente a 6 bar.  
Cycle time w/o resistant torque at 6 bar.

Dimensiones en mm.  
Dimensions in mm.

Para calcular el consumo, multiplicar las cifras del cuadro por la presión real de trabajo.

To calculate the consumption, multiply the above figures by the real working pressure.

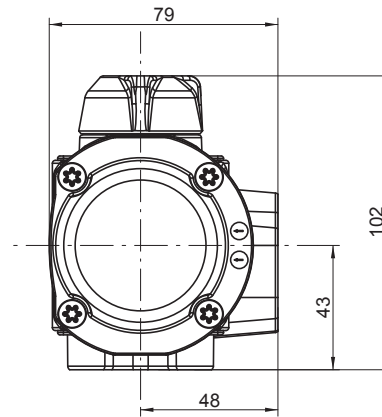
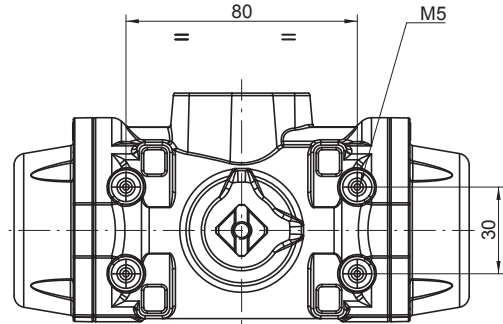
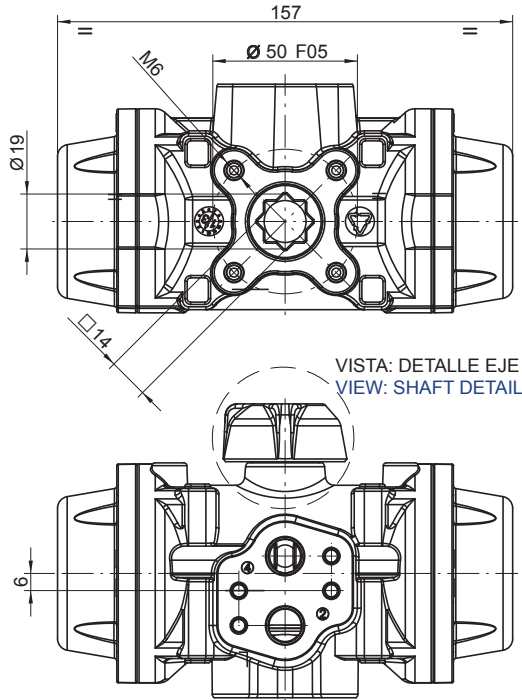

### PARES DOBLE EFECTO DOUBLE ACTING TORQUES

PP00	PRESION AIRE AIR PRESSURE						
bar	3	4	5	5,5	6	7	8
p.s.i	43,5	58	72,5	79,8	87	101,5	116
Nm	13,3	18,3	23,4	26	28,5	33,6	38,7
Lb.in	117,7	162	207,1	230,1	252,2	297,4	342,5

### PARES SIMPLE EFECTO SPRING RETURN TORQUES

PP00S	PAR MUELLES SPRING TORQUES		PAR A LA PRESIÓN INDICADA AIR TORQUE AT INDICATED PRESSURE																
			3		4		5		5,5		6		7		8		bar		
N	INICIAL INITIAL	FINAL END	43,5		58		72,5		79,8		87		101,5		116		p.s.i		
6*	18,8	12,7							10,7	4,6	13,3	7,2	15,8	9,7	20,9	14,8	26	19,9	Nm
	166,4	112,4							94,7	40,7	117,7	63,7	139,8	85,8	185,0	131,0	230,1	176,1	Lb.in
5	15,8	10,7			7,6	2,5	12,7	7,6	15,3	10,2	17,8	12,7	22,9	17,8	28	22,9			Nm
	139,8	94,7			67,3	22,1	112,4	67,3	135,4	90,3	157,5	112,4	202,7	157,5	247,8	202,7			Lb.in
4	12,6	8,7			9,6	5,7	14,7	10,8	17,3	13,4	19,8	15,9	24,9	21	30	26,1			Nm
	111,5	77			85,0	50,4	130,1	95,6	153,1	118,6	175,2	140,7	220,4	185,9	265,5	231,0			Lb.in
3	9,7	6,6	6,7	3,6	11,7	8,6	16,8	13,7	19,4	16,3	21,9	18,8	27	23,9	32,1	29			Nm
	85,8	58,4	59,3	31,9	103,5	76,1	148,7	121,2	171,7	144,3	193,8	166,4	239	211,5	284,1	256,7			Lb.in
2	6,6	4,1	9,2	6,7	14,2	11,7	19,3	16,8	21,9	19,4	24,4	21,9	29,5	27	34,6	32,1			Nm
	58,4	36,3	81,4	59,3	125,7	103,5	170,8	148,7	193,8	171,7	215,9	193,8	261,1	239	306,2	284,1			Lb.in

N: Número de muelles por banda  
Number of springs per side

\* Número de muelles estándar  
\* Standard number of springs

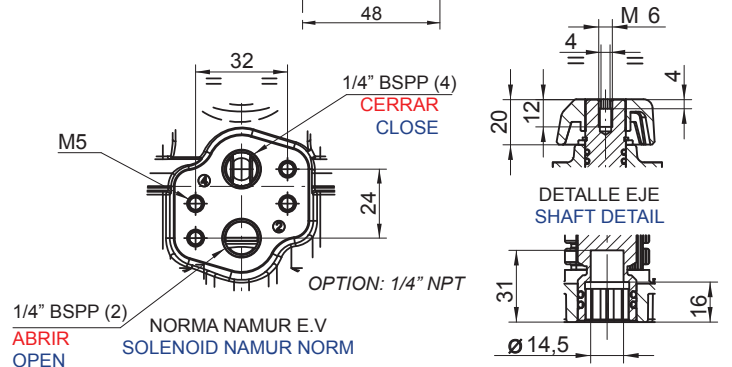



DESPIECE

DISASSEMBLY



ACTUADOR NEUMÁTICO DE POLIAMIDA  
POLYAMIDE PNEUMATIC ACTUATOR



PP10: Doble Efecto / Double Acting

PP10S: Simple Efecto / Spring Return

Nº	Descripción Description	Cant. Quant.	Material Material
1	TORNILLO AVELLANADO TAPA CAP COUNTERSUNK SCREW	8	ACERO INOX. AISI-304 AISI-304 STAINLESS STEEL
2	TAPA CAP	2	POLIAMIDA + FV POLYAMIDE + FG
3	JUNTA TÓRICA TAPA CAP O-RING	2	N.B.R. N.B.R.
4	ÉMBOLO PISTON	2	POLIARILAMIDA POLYARILAMIDE
5	CILINDRO CYLINDER	1	POLIAMIDA + FV POLYAMIDE + FG
6	ARANDELA WASHER	1	POLIACETAL POLYACETAL
7	ANILLO DE SEGURIDAD SPRING CLIP	1	ACERO INOXIDABLE STAINLESS STEEL
8	INDICADOR VISUAL POSITION INDICATOR	1	POLIAMIDA POLYAMIDE
9	GUIA ÉMBOLO PISTON GUIDE	2	POLIACETAL POLYACETAL
10	ANILLO GUIA GUIDE RING	2	POLIACETAL POLYACETAL
11	JUNTA TÓRICA ÉMBOLO PISTON O-RING	2	N.B.R. N.B.R.
12	JUNTA TÓRICA O-RING	2	N.B.R. N.B.R.
13	JUNTA TÓRICA O-RING	2	N.B.R. N.B.R.
14	MUELLES PRECARGADOS PRELOADED SPRINGS	12	DIN-17223-C (6) (4) DIN-17223-C (6) (4)
15	PROTECTOR / TUERCA PROTECTOR / NUT	8	POLIAMIDA / INOX AISI-304 POLYAMIDE / S.S AISI-304
16	EJE SHAFT	1	ACERO INOX. AISI-303 AISI-303 STAINLESS STEEL
17	PIÑÓN GEAR	1	ALEACIÓN DE ALUMINIO (5) ALUMINIUM ALLOY (5)
18	INSERTOS ROSCADOS THREAD INSERTS	10	ACERO INOXIDABLE STAINLESS STEEL

- (4) CANTIDAD VARIABLE, CONSULTAR TABLAS PARES SIMPLE EFECTO.  
VARIABLE QUANTITY, PLEASE SEE THE SPRING RETURN TORQUE CHART.
- (5) BRUÑIDO CON BOLAS.  
BALL BURNISHING.
- (6) PASIVADO DE CROMO TRIVALENTE.  
TRIVALENT CHROMINIUM PASSIVATION.

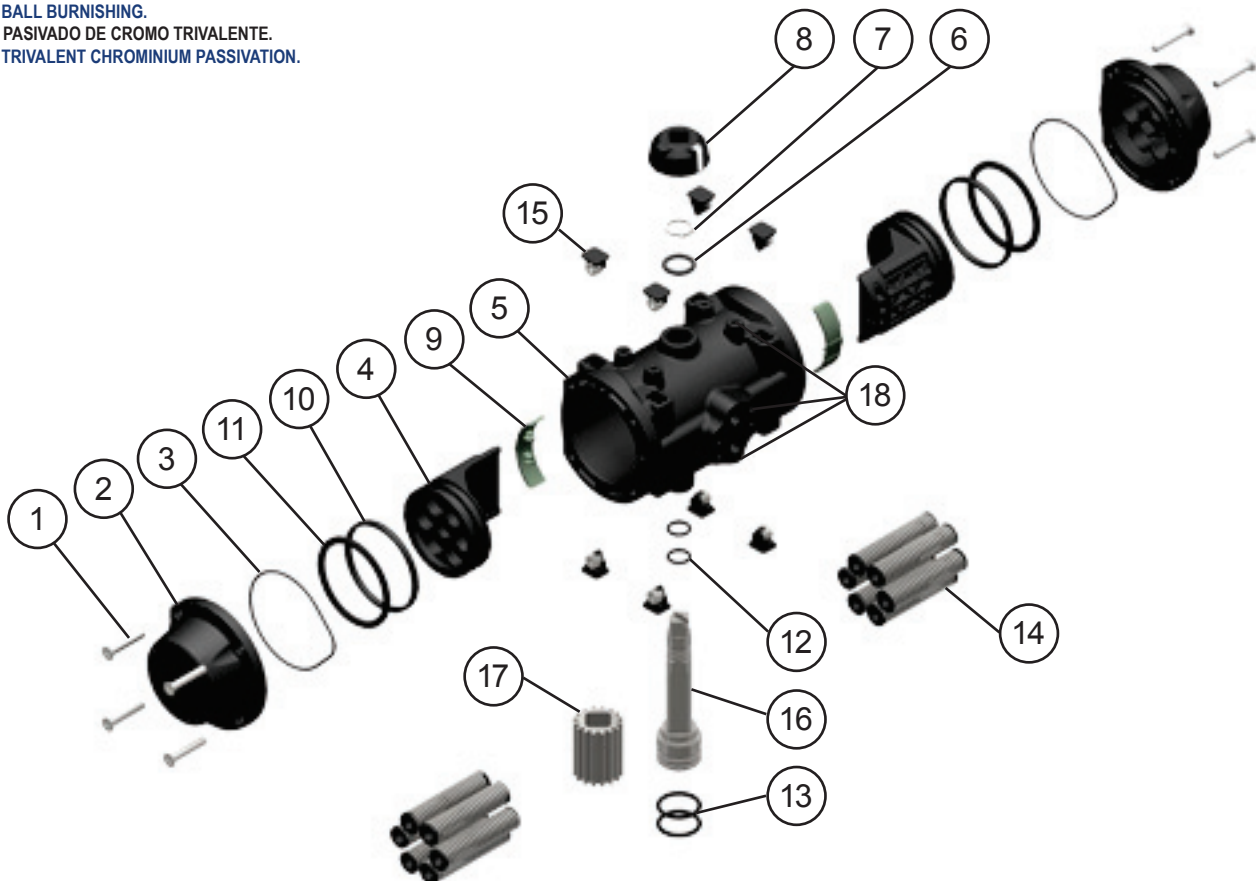

MODELOS MODELS	TIEMPO DE MANIOBRA EN SEG. CYCLE TIME IN SECS.		PESOS WEIGHTS		CAPACIDAD EN LITROS CAPACITY IN LITRES	
	PARA ABRIR TO OPEN	PARA CERRAR TO CLOSE	Kg.	Lb.	PARA ABRIR TO OPEN	PARA CERRAR TO CLOSE
PP10	0,25	0,25	1,65	3,64	0,35	0,45
PP10S	0,3	0,3	2,03	4,48	0,35	

Tiempo de maniobra sin par resistente a 6 bar.  
Cycle time w/o resistant torque at 6 bar.

Dimensiones en mm.  
Dimensions in mm.

Para calcular el consumo, multiplicar las cifras del cuadro por la presión real de trabajo.

To calculate the consumption, multiply the above figures by the real working pressure.

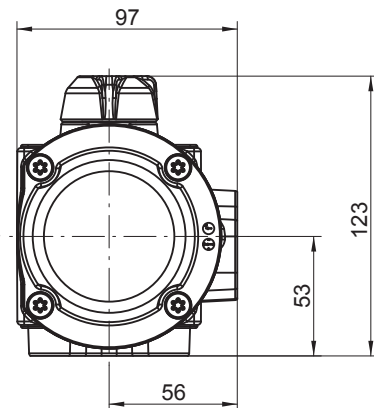
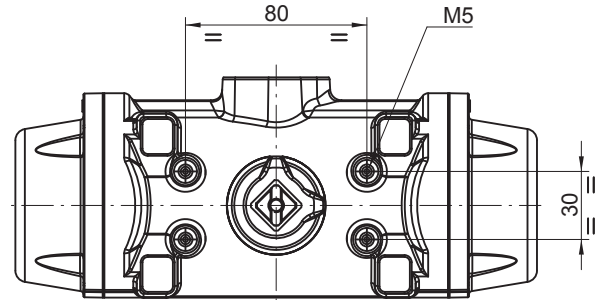
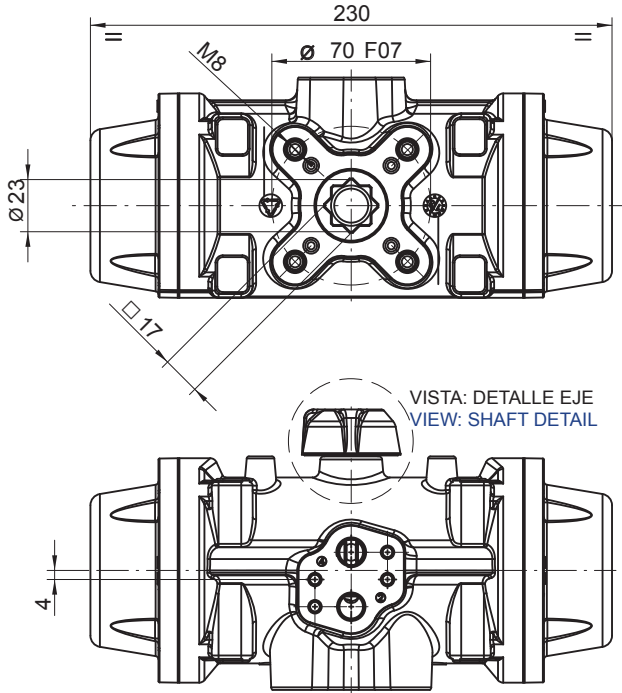

### PARES DOBLE EFECTO DOUBLE ACTING TORQUES

PP10	PRESION AIRE AIR PRESSURE						
bar	3	4	5	5,5	6	7	8
p.s.i	43,5	58	72,5	79,8	87	101,5	116
Nm	32,9	45,6	58,3	65	71	83,7	96,4
Lb.in	291	404	516	575	628	741	853

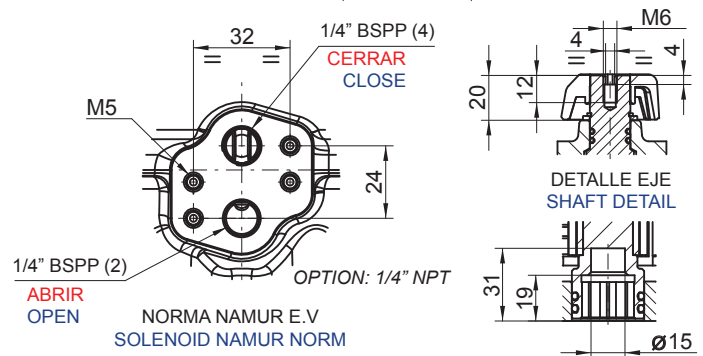

### PARES SIMPLE EFECTO SPRING RETURN TORQUES

PP10S	PAR MUELLES SPRING TORQUES		PAR A LA PRESIÓN INDICADA AIR TORQUE AT INDICATED PRESSURE														
			3		4		5		5,5		6		7		8		bar
		43,5		58		72,5		79,8		87		101,5		116		p.s.i	
N	INICIAL INITIAL	FINAL END	INICIAL INITIAL	FINAL END	INICIAL INITIAL	FINAL END	INICIAL INITIAL	FINAL END	INICIAL INITIAL	FINAL END	INICIAL INITIAL	FINAL END	INICIAL INITIAL	FINAL END	INICIAL INITIAL	FINAL END	
6*	45,6	30,8					27,5	12,7	34,2	19,4	40,2	25,4	52,9	38,1	65,6	50,8	Nm
	403,6	272,6					243,4	112,4	302,7	171,7	355,8	224,8	468,2	337,2	580,6	449,6	Lb.in
5	38	25,7			19,9	7,6	32,6	20,3	39,3	27	45,3	33	58	45,7	70,7	58,4	Nm
	336,3	227,5			176,1	67,3	288,5	179,7	347,8	239	400,9	292,1	513,3	404,5	625,7	516,9	Lb.in
4	30,4	20,5	12,4	2,5	25,1	15,2	37,8	27,9	44,5	34,6	50,5	40,6	63,2	53,3	75,9	66	Nm
	269,1	181,4	109,7	22,1	222,2	134,5	334,6	246,9	393,9	306,2	447	359,3	559,4	471,7	671,8	584,1	Lb.in
3	22,8	15,4	17,5	10,1	30,2	22,8	42,9	35,5	49,6	42,2	55,6	48,2	68,3	60,9			Nm
	201,8	136,3	154,9	89,4	267,3	201,8	379,7	314,2	439	373,5	492,1	426,6	604,5	539,0			Lb.in
2	15,2	10,3	22,6	17,7	35,3	30,4	48	43,1	54,7	49,8	60,7	55,8					Nm
	134,5	91,2	200	156,7	312,4	269,1	424,8	381,5	484,1	440,8	537,2	493,9					Lb.in

N: Número de muelles por banda  
Number of springs per side

\* Número de muelles estándar  
\* Standard number of springs

DESPIECE

DISASSEMBLY



ACTUADOR NEUMÁTICO DE POLIAMIDA  
POLYAMIDE PNEUMATIC ACTUATOR



PP20: Doble Efecto / Double Acting

PP20S: Simple Efecto / Spring Return

Nº	Descripción Description	Cant. Quant.	Material Material
1	TORNILLO AVELLANADO TAPA CAP COUNTERSUNK SCREW	8	ACERO INOX. AISI-304 AISI-304 STAINLESS STEEL
2	TAPA CAP	2	POLIAMIDA + FV POLYAMIDE + FG
3	JUNTA TÓRICA TAPA CAP O-RING	2	N.B.R N.B.R
4	ÉMBOLO PISTON	2	POLIARILAMIDA POLYARILAMIDE
5	CILINDRO CYLINDER	1	POLIAMIDA + FV POLYAMIDE + FG
6	ARANDELA WASHER	1	POLIACETAL POLYACETAL
7	ANILLO DE SEGURIDAD SPRING CLIP	1	ACERO INOXIDABLE STAINLESS STEEL
8	INDICADOR VISUAL POSITION INDICATOR	1	POLIAMIDA POLYAMIDE
9	GUIA ÉMBOLO PISTON GUIDE	2	POLIACETAL POLYACETAL
10	ANILLO GUIA GUIDE RING	2	POLIACETAL POLYACETAL
11	JUNTA TÓRICA ÉMBOLO PISTON O-RING	2	N.B.R. N.B.R.
12	JUNTA TÓRICA O-RING	2	N.B.R. N.B.R.
13	JUNTA TÓRICA O-RING	2	N.B.R. N.B.R.
14	MUELLES PRECARGADOS PRELOADED SPRINGS	12	DIN-17223-C (6) (4) DIN-17223-C (6) (4)
15	PROTECTOR / TUERCA PROTECTOR / NUT	8	POLIAMIDA / INOX AISI-304 POLYAMIDE / S.S AISI-304
16	EJE SHAFT	1	ACERO INOX. AISI-303 AISI-303 STAINLESS STEEL
17	PIÑÓN GEAR	1	ALEACIÓN DE ALUMINIO (5) ALUMINIUM ALLOY (5)
18	INSERTOS ROSCADOS THREAD INSERTS	10	ACERO INOXIDABLE STAINLESS STEEL

- (4) CANTIDAD VARIABLE, CONSULTAR TABLAS PARES SIMPLE EFECTO.  
VARIABLE QUANTITY, PLEASE SEE THE SPRING RETURN TORQUE CHART.
- (5) BRUÑIDO CON BOLAS.  
BALL BURNISHING.
- (6) PASIVADO DE CROMO TRIVALENTE.  
TRIVALENT CHROMINIUM PASSIVATION.

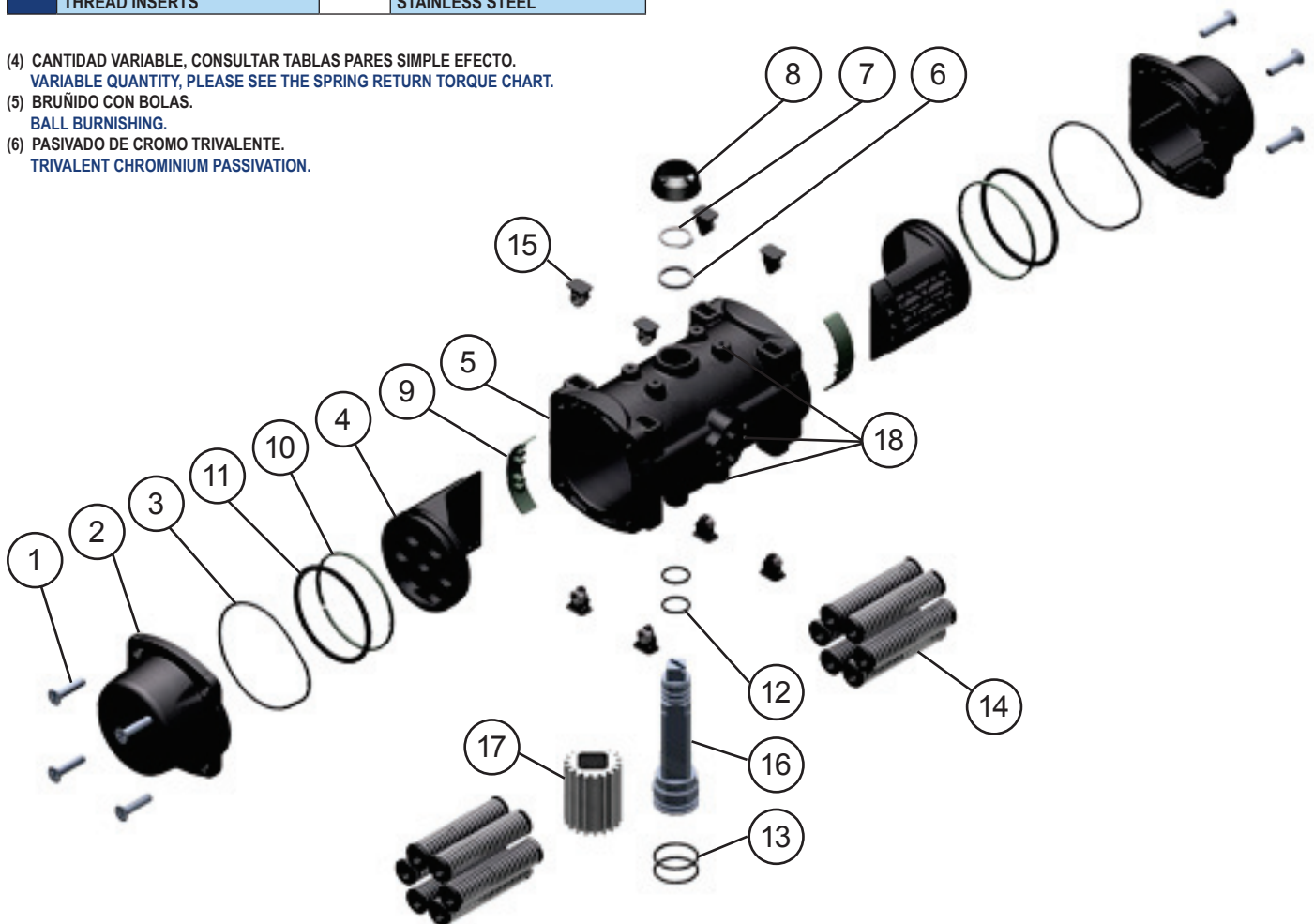

MODELOS MODELS	TIEMPO DE MANIOBRA EN SEG. CYCLE TIME IN SECS.		PESOS WEIGHTS		CAPACIDAD EN LITROS CAPACITY IN LITRES	
	PARA ABRIR TO OPEN	PARA CERRAR TO CLOSE	Kg.	Lb.	PARA ABRIR TO OPEN	PARA CERRAR TO CLOSE
PP20	0,4	0,4	3,22	7,1	0,8	1,15
PP20S	0,5	0,5	4,22	9,3	0,8	-

Tiempo de maniobra sin par resistente a 6 bar.  
Cycle time w/o resistant torque at 6 bar.

Dimensiones en mm.  
Dimensions in mm.

Para calcular el consumo, multiplicar las cifras del cuadro por la presión real de trabajo.

To calculate the consumption, multiply the above figures by the real working pressure.

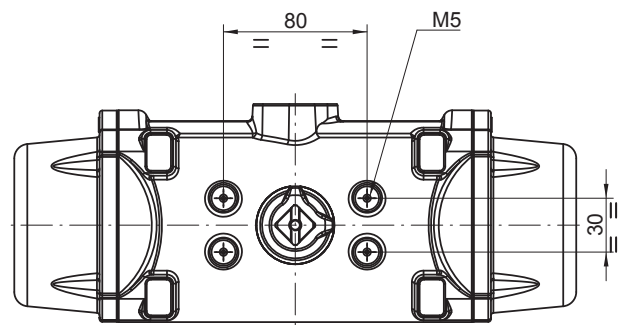
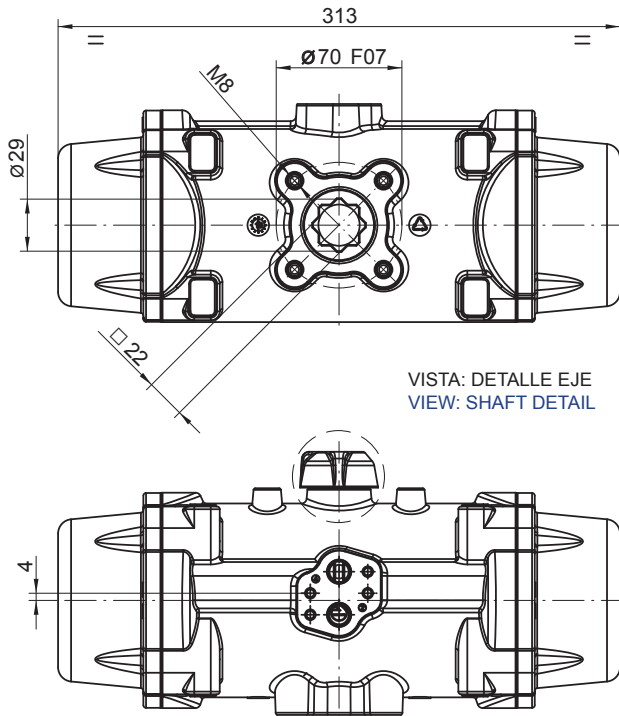

### PARES DOBLE EFECTO DOUBLE ACTING TORQUES

PP20	PRESION AIRE AIR PRESSURE						
bar	3	4	5	5,5	6	7	8
p.s.i	43,5	58	72,5	79,8	87	101,5	116
Nm	77,7	107	136,3	150,9	165,4	194,8	224
Lb.in	687,8	947,3	1.206	1.335	1.465	1.724	1.983

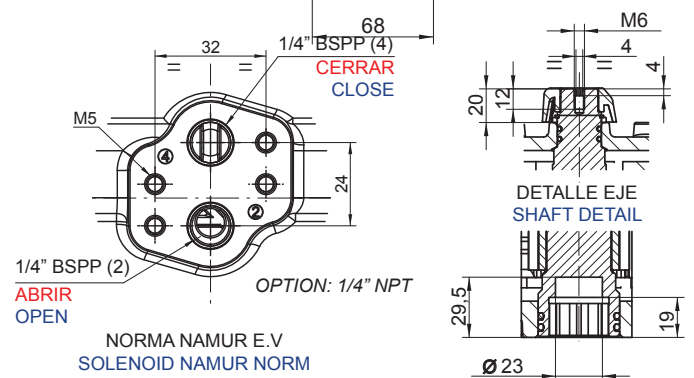

### PARES SIMPLE EFECTO SPRING RETURN TORQUES

PP20S	PAR MUELLES SPRING TORQUES		PAR A LA PRESIÓN INDICADA AIR TORQUE AT INDICATED PRESSURE														
			3		4		5		5,5		6		7		8		bar
N	INICIAL INITIAL	FINAL END	43,5		58		72,5		79,8		87		101,5		116		p.s.i
6*	104,7	65,8					70,5	31,6	85,2	46,3	99,7	60,8	129	90,1	158,2	119,3	Nm
	926,7	582,4					624	279,7	754,1	409,8	882,4	538,1	1.142	797	1.400	1.056	Lb.in
5	87,2	54,8			52,2	19,8	81,5	49,1	96,2	63,8	110,7	78,3	140	107,6	169,2	136,8	Nm
	771,8	485			462	175	721,3	434,6	851,4	564,7	980	693	1.239	952,3	1.497	1.211	Lb.in
4	69,8	43,9	33,8	8	63,1	37,2	92,4	66,5	107,1	81,2	121,6	95,7	150,9	125	180,1	154,2	Nm
	617,8	388,5	299,2	69,9	558,5	329,2	817,8	588,6	947,9	718,7	1.076	847	1.336	1.106	1.594	1.365	Lb.in
3	52,3	32,9	44,8	25,4	74,1	54,7	103,4	84	118,1	98,7	132,6	113,2	161,9	142,5			Nm
	462,9	291,2	396,5	224,8	655,8	484,1	915,2	743,5	1045	873,6	1.174	1.002	1.433	1.261			Lb.in
2	34,9	21,9	55,8	42,8	85,1	72,1	114,4	101,4	129,1	116,1	143,6	130,6					Nm
	308,9	193,8	493,9	378,8	753,2	638,1	1.012	897,5	1.143	1.027	1.271	1.156					Lb.in

N: Número de muelles por banda  
Number of springs per side

\* Número de muelles estándar  
\* Standard number of springs